

Instrument Meter Specialties, Inc.
 1-800-926-3837..... 1-818-243-0416



We Accept:
 Visa - MasterCard
 Amex - Discover

**Rectangular
 Analog Panel Meters**

Dimensions and Compatibility

2-1/2"-Model 147 & 157

1 = Panel Meter Cut-out Dimensions

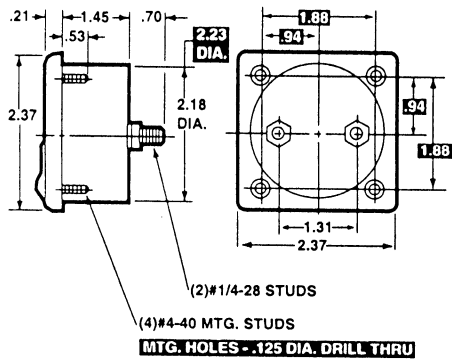

3-1/2"-Model 47 & 57

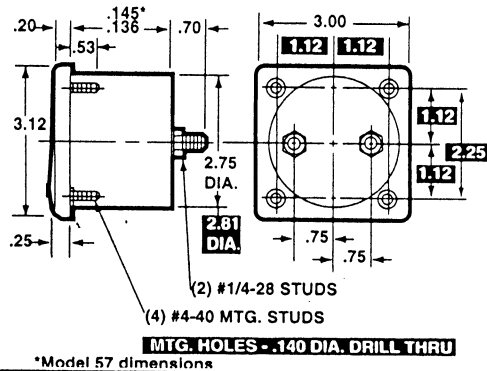

4-1/2"-Model 49 & 59

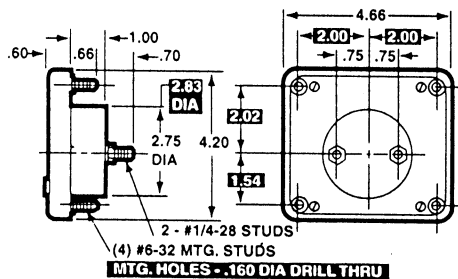

Compatibility Reference Table

Manufacturer	Size/Model		
	2-1/2"	3-1/2"	4-1/2"
Beede		15	16/458
Hoyt		598	648/684
Modutec PB Series	2PB*	3PB*	4PB
Triplet S Series	227-T	327-*T	420
Yokogawa Big Look	250-2 OPT.	250-3 OPT.	250-4 OPT. 1

*Modutec Meters use a three-stud mount.

Specifications

Accuracy: ±2% full scale (F.S.) (iron-vane), ±3% (rectifier)
Movement: Models 57, 59, 157: Iron-vane, magnetically damped
 Models 47, 49, 147: Annular, rectifier type, self-shielding
Suspension: Pivot and jewel
Tracking: ±3%
Shielding: Calibration is unaffected by magnetic panel mounting
Response Time: 1.5 seconds maximum
Overload (1 sec.): 10 times F.S.
Overload (Continuous): 1.5 times F.S.
Repeatability: 2%
Dial: Sharp clear scale. Each dial arc is calibrated to track the specific type of movement used.

Case: High density black phenolic
Resistance: ±15%
Operating Temperature: -4°F to +149°F (-20°C to +65°C)
Pointer: Spade pointer, with black matte finish
Scale Length: Model 47: 2.5" (63.5mm); Model 49: 3.9" (99mm)
 Model 57: 2.3" (58.4mm); Model 59: 3.5" (89.0mm);
 Model 147: 1.8" (45.7mm); Model 157: 1.6" (40.6mm)
Net Weight: Models 47 & 59: 8oz (0.23kg)
 Models 57 & 157: 5oz (0.14kg)
 Models 147: 7oz (0.20kg)
 Model 49: 11oz (0.31kg)