



NK Technologies

AT/ATR 3 & 4 Series

'AT/ATR 3 & 4' transducers from NK Technologies combine a high capacity current transformer and a signal conditioner into a single package. The AT version is Average Responding for use on linear (sinusoidal) loads. The ATR version is True RMS for use on distorted waveforms found in VFD or SCR outputs. Available in a solid or split core case.



Shown with solid core case.

High Current Transducers

Applications

Large Pumps

Detect dry run electronically.

Generation

Measure the output of generators.

Electric Heating Elements

- Monitors heater load.
- Faster response than temperature sensors.

Features

Large Aperture

Accommodates large conductors or wire bundles.

Select the Right Output

True RMS technology is accurate on distorted waveforms like VFD or SCR outputs. Average Responding—for linear, sinusoidal waveforms

Three Jumper Selectable Ranges

- Reduces inventory.
- Eliminates zero and span pots.

Isolation

Magnetic isolation protects installers and systems.

Easy Installation

Single piece with integral mounting brackets makes for a simple, solid installation.

UL, CUL and CE Approval

Accepted worldwide.

Selecting the right transducer:

The current waveform of a typical linear load is a pure sine wave. AT transducers measure the peaks of these sine waves, then calculate the average amperage. This works well on constant speed linear loads in a "clean" power environment. *Select AT transducers for strictly linear loads on "clean" power.*

VFD and SCR output waveforms are rough approximations of a sine wave. There are numerous spikes and dips in each cycle. ATR Transducers use a mathematical algorithm called "True RMS," which integrates the actual waveform over time. The output is the amperage component of the true power (heating value) of the AC current waveform. True RMS is the only way to accurately measure distorted AC waveforms. *Select ATR transducers for nonlinear loads on "noisy" power.*

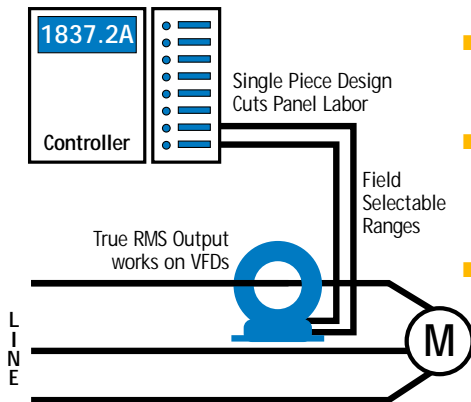

High Current Transducers

ATR 3 & 4 Series

Know your power...

because with knowledge comes control.

Specifications

Output Signal	4–20mA, Loop-powered
Output Limit	23mA
Accuracy	1.0% FS accuracy, True RMS
Measurement	True RMS or Average Responding (see Ordering Information)
Response Time	500mS (to 90% of step change)
Frequency Range	<ul style="list-style-type: none"> ■ ATR: 10–400Hz ■ AT: 50–60Hz, Sinusoidal
Power Supply	24VDC Nominal; 40VDC Maximum
Isolation Voltage	600VAC
Input Ranges	<ul style="list-style-type: none"> ■ AT/ATR3: 375, 500, 750A ■ AT/ATR4: 1000, 1333, 2000A
Sensing Aperture	3.0" (76mm) dia.
Case	UL 94 Flammability rated
Environmental	–4 to 122°F (–20 to 50°C), 0–95% RH, non-condensing
Listings	UL 508 Industrial Control Equipment (USA & Canada), CE (Pending)

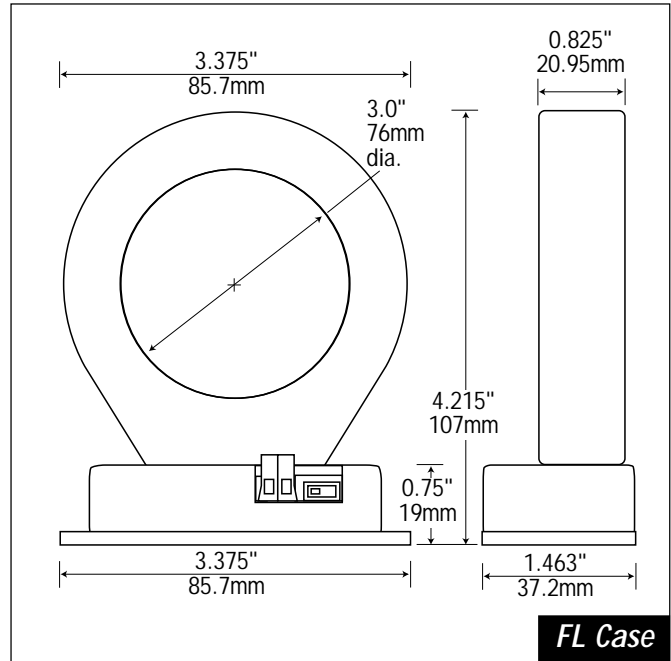

FL Case

Power Supply

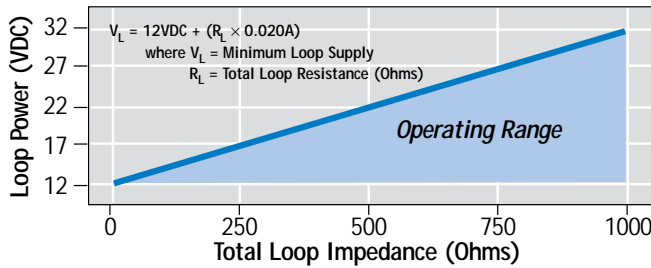

Connections

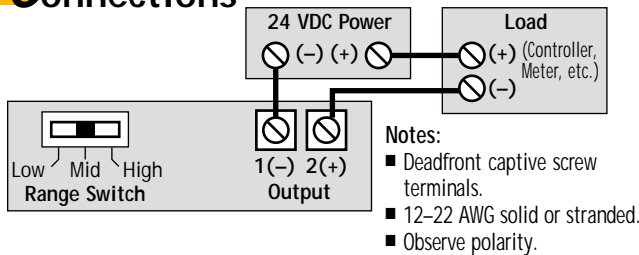

Ordering Information

Example: ATR3-420-24L-FL
 True RMS AC current transducer, 24VDC powered with a 4–20mA output, 375, 500 and 750 amp range in a fixed core case.*

AT	–	–	420	–	24L	–	FL
Measurement	–	Full Scale	Output Signal	–	Power Supply	–	Case*
R True RMS	–	Ranges	420 4–20mA	–	24L 24VDC	–	FL Fixed Core
– Average Responding (Blank)	–	3 375, 500, 750A 4 1000, 1333, 2000A	–	–	Loop-powered	–	–

*Split core version available in the Spring of 2000.

High Current Transducers
ATR 3 & 4 Series